



Highlands East Building Department
1032 Gooderham St.
Box 22 Gooderham, ON K0M 1R0
705-447-0051

APPLICATION GUIDELINES FOR A DECK

Application for Permit

To obtain a permit under Subsection 8(1) of the Act, the applicant shall file an application in writing by completing a prescribed provincial application form available from the Municipality of Highlands East website or the Highlands East Building Department at 1032 Gooderham St. Gooderham.

Additional Permits

The following permits, where applicable, are required to accompany an application for building permit:

- 1) Conservation Authority Approval: To be obtained from the Crowe Valley Conservation Authority.
- 2) Other permits as may be required.

Required Plans

Drawings, plans and specifications to accompany an application to permit. **All drawings MUST be clear, legible, accurate, drawn to scale and conform to the Ontario Building Code.**

- 1) **Site Plan**
 - Lot area and dimensioned property lines
 - Direction north indicated
 - Size and use of all existing and proposed structures including location of all structures with dimensions to property lines
 - Location of septic system/well with measurements to lot lines and structures
 - Location of driveway and parking areas
 - Location of easements, right-of-ways, overhead power lines, etc.
- 2) **Foundation Plan** (minimum scale: 3/16"=1'-0" or 1:75 (metric))
 - Footings supporting walls, pilasters, columns and piers
 - Foundation walls and supporting structure including construction types and material
 - Floor framing above including all proprietary layouts, details and specifications
 - Building section and detail markers
- 3) **Floor Plans** (minimum scale: 3/16"=1'-0" or 1:75 (metric))
 - Stair, landing, guard and handrail location, type, material, etc.
 - Building section and detail markers
- 4) **Sections and Details** (minimum scale: 1/4"=1'-0" or 1:50 (metric))
 - Stair, landing, guard and handrail details, etc.
 - Dimensioned finished grade to deck platform height(s)

General Notes:

- 1) The permit application shall include 2 complete sets of fully dimensioned construction drawings. A non-refundable application fee of \$75.00 shall accompany the application for permit
- 2) All drawings and specifications are to be project specific.
- 3) Refer to our zoning by-law, available on our web site (www.highlandseast.ca) for setback information, restrictions to location, size, height, etc.
- 4) All drawings are to be drawn to scale. The scale shall be noted on the drawings.
- 5) **DO NOT** include presentation graphics (furniture, etc.) on construction drawings.
- 6) Where the proposed deck is to be constructed within 1 metre of a required setback or survey monuments are not visible, verification of setback **MUST** be provided by an Ontario Land Surveyor prior to footing inspection.
- 7) If the deck surface is more than 2'-0" and less than 5'-11" above finished ground level, a minimum 36" high guard is required. If the deck surface is 5'-11" or more above finished ground level, a minimum 42" high guard is required. Guards are required on stairs where the deck height is 24" or more above finished ground level. No opening in the guard shall exceed 4". Guards shall be designed such that no member, attachment or opening between 5 1/2" and 35 "above the deck surface will facilitate climbing.
- 8) Stairs with more than 3 risers require a handrail on at least one side.
- 9) Decks attached to an adjacent structure shall be constructed on foundations that extend to minimum 48" below finished ground level.
- 10) Concrete piers shall be minimum 10" in diameter where the supported post is 6X6.
- 11) Where 5/4 decking is proposed, the decking shall be installed perpendicular to the joists where the joists are spaced at 16: o/c. Decking may be installed at an angle of 45 degrees to the deck joist where the deck joists are spaced not more than 12" o/c or 2x6 decking is used.

12) Required Inspections:

- Footing: After excavation of post holes, prior to the placement of concrete.
- Framing: After framing is complete, prior to the installation of decking and....
- Final: Upon completion of deck, **PRIOR TO USE.**

Note: Inspections will be conducted within 2 business days from receipt of notice and on assigned days.

13) Doors providing access to the proposed deck shall be secured or blocked to prevent access to deck until final approval for the deck has been granted by the Chief Building Official.

Information Package for Decks and Porches

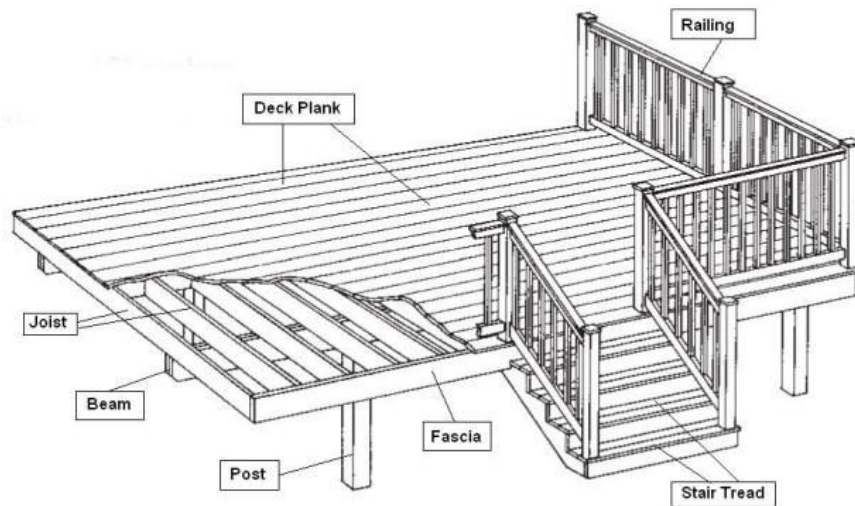

DEFINITIONS

Deck: A raised uncovered platform that is attached to a dwelling. To ensure conformity contact office to see if a permit is required. Protective guards are required if the walking surface is greater than 24" (610mm) above finished grade.

Porch: A covered structure (enclosed or unenclosed) that usually forms part of the entrance to a dwelling. Porches require a Building Permit issued by the Building Department. Protective guards are required if the walking surface is greater than 24" (610mm) above finished grade.

Patio: An uncovered platform at grade level that is constructed of concrete or stone. A patio generally does not require a Building Permit, unless it interferes with an existing structure.

Joist: Dimensional lumber placed perpendicular to beam that frames the floor system.

Beam: Laminated dimensional lumber that supports the joists.

OBC: Refers to the current amended version of the Ontario Building Code.

Guard: Refers to a protective barrier around decks, porches and the open side of stairs.



Construction Information

Piers: Shall not be less than 8" (203mm) in diameter. Under most circumstances it may be preferable to expand the lower portion of a small pier to achieve the required bearing area rather than use a larger pier. Refer to the table below for minimum footing sizes. Values in table are based on soil bearing capacity of 10.9psi (75kPa). Minimum sizes must be double where the solid bearing capacity is affected by a high water table.

10.9 psi Soil Bearing Capacity		MINIMUM REQUIRED BEARING, (ft ²)					
		Beam Length/Pier Spacing, (ft)					
		4'-0"	6'-0"	8'-0"	10'-0"	12'-0"	14'-0"
Supported Joist Length,* (ft)	4'-0"	0.43 ft ² (10"Ø or 8"x8")	0.65 ft ² (12"Ø or 10"x10")	0.86 ft ² (14"Ø or 12"x12")	1.08 ft ² (14"Ø or 13"x13")	1.29 ft ² (16"Ø or 14"x14")	1.51 ft ² (18"Ø or 15"x15")
	6'-0"	0.65 ft ² (12"Ø or 10"x10")	0.97 ft ² (14"Ø or 12"x12")	1.29 ft ² (16"Ø or 14"x14")	1.61 ft ² (18"Ø or 16"x16")	1.94 ft ² (20"Ø or 17"x17")	2.26 ft ² (22"Ø or 19"x19")
	8'-0"	0.86 ft ² (14"Ø or 8"x8")	1.29 ft ² (16"Ø or 14"x14")	1.72 ft ² (18"Ø or 16"x16")	2.15 ft ² (20"Ø or 18"x18")	2.58 ft ² (22"Ø or 20"x20")	3.01 ft ² (24"Ø or 21"x21")
	10'-0"	1.08 ft ² (14"Ø or 13"x13")	1.61 ft ² (18"Ø or 16"x16")	2.15 ft ² (20"Ø or 18"x18")	2.69 ft ² (24"Ø or 20"x20")	3.23 ft ² (NA or 22"x22")	3.76 ft ² (NA or 24"x24")
	12'-0"	1.29 ft ² (16"Ø or 14"x14")	1.94 ft ² (20"Ø or 17"x17")	2.58 ft ² (22"Ø or 20"x20")	2.82 ft ² (24"Ø or 21"x21")	3.87 ft ² (NA or 24"x24")	4.52 ft ² (NA or 26"x26")
	14'-0"	1.51 ft ² (18"Ø or 16"x16")	2.26 ft ² (22"Ø or 18"x18")	3.01 ft ² (24"Ø or 21"x21")	3.76 ft ² (NA or 24"x24")	4.52 ft ² (NA or 26"x26")	5.27 ft ² (NA or 28"x28")
	16'-0"	1.72 ft ² (18"Ø or 16"x16")	2.58 ft ² (22"Ø or 20"x20")	3.44 ft ² (NA or 23"x23")	4.30 ft ² (NA or 25"x25")	5.16 ft ² (NA or 28"x28")	6.02 ft ² (NA or 30"x30")

* Supported Length means half the sum of the joists supported by the beam & ledger board plus any cantilever.

Concrete: Piers shall consist of poured concrete with a minimum compressive strength of 2200 psi (15 MPa) after 28 days [OBC 9.3.1.3]

Depth: Where a deck or porch is attached to a dwelling the minimum shall be 47" (1.2 m). There is no minimum footing depth required for an uncovered deck that is not attached to another structure and is constructed where the finished grade is less than 24" (610mm) [OBC 9.12.2.2]

Height: Piers shall not extend more than 3 times their width above finished grade [OBC 9.15.2.3 (3)]

Columns: Round wood columns shall not be less than 7 1/4" Ø (184mm Ø) or 5 1/2" x 5 1/2" (140 mm x 140 mm) square [OBC 9.17.4.1(2)]

Anchorage: Columns shall be directly fastened to their supports as well as to the framing members for which they are supporting to resist uplift and lateral movement [OBC 9.23.6.2].

Ledger Board: Shall consist of the same nominal sized lumber as the deck joist and contain joist hangers to support the deck joists. These hangers shall be coated to prevent corrosion and installed as per manufacturer's specifications.

Ledger Anchorage: Anchorage for ledger boards shall consist of expandable sleeve anchors for solid concrete or concrete filled masonry or carriage bolts with nuts and washers into suitable structural lumber. In all cases they shall be embedded minimum 4" (100 mm). Refer to the table below for size and spacing.

Supported Length* (ft)	Maximum Bolt Spacing, (ft)	
	Staggered 1/2"Ø	Staggered 5/8"Ø
3'-11"	1'-5 3/4"	1'-8"
4'-9"	1'-4"	1'-5 3/4"
6'-6"	1'-0"	1'-4"
8'-2"	11"	1'-0 3/4"

* Supported Length means half the sum of the joist span.

Joists: May be supported on either the top of a built-up beam or joist hanger coated to prevent corrosion and installed as per the manufacturer's specifications. At no time shall the minimum bearing of the joists be less than 1 1/2 "(38mm). Each joist bearing on a built up beam must be mechanically fastened to the beam with two (2) galvanized framing nails 3 1/4 (82 mm) in length. Refer to the table below for maximum size and spacing of joists.

Joist Size	Maximum Joist Span*, (ft)		
	12" on centre	16" on centre	24" on centre
2x6	10'-3"	9'-4"	8'-2"
2x8	12'-6"	11'-9"	10'-8"
2x10	14'-6"	13'-8"	12'-10"
2x12	16'-5"	15'-5"	14'-6"

* Spans based on Spruce-Pine-Fir (SPF) Grade No1 or No2

Beams: Built-up beams shall have not less than 3 1/2" (89mm) of bearing and be fully supported over their width [OBC 9.23.8.1.]. Where individual members are butted together to form a joist, the joint must occur over the support. Built-up beams shall be nailed together with a double row of galvanized framing nails not less than 3 1/2 "(89mm) in length. Spacing shall not be more than 18" (450 mm) apart and not more than 4" (100 mm) from the end [OBC 9.23.8.3.(7).] Refer to the table below for maximum built-up beam size and length.(see Fig E)

Supported Length,* (ft)	Maximum Beam Span, (ft)		
	3-2x8	3-2x10	3-2x12
7'-10 1/2"	10'-0"	12'-10"	14'-11"
9'-10 1/8"	9'-4"	11'-6"	13'-5"
11'-9 3/4"	8'-7"	10'-6"	12'-2"
13'-9 3/8"	8'-0"	9'-9"	11'-4"
15'-9"	7'-5"	9'-1"	10'-7"
17'-8 5/8"	7'-0"	8'-7"	10'-0"
19'-8 1/4"	6'-8"	8'-2"	9'-5"

* Supported Length means half the sum of the joists supported by the beam & ledger board plus any cantilever.

Cantilever: 2x8 (38 mm x 184 mm) joists supporting roof loads shall not cantilever more than 16" (400 mm) beyond their supports. Joists sizes larger than 2x8 shall not cantilever more than 25" (600mm) beyond their supports [OBC 9.23.9.9.]

Blocking: Where joist spans are greater than 6'-11" (2.1 m) cross bridging or solid blocking shall be provided at mid span. Cross bridging or solid blocking shall be:

- 1x3 (19mm x 64mm) cross bridging,
- 2x2 (38mm x 38mm) Cross bridging or,
- solid blocking the same size joists.

Bridging or blocking shall be fastened with two (2) galvanized framing nails 2 ¼ "(57 mm) in length at each end.

Decking: Plank type decking less than or equal to 7 ¼ "(184 mm) wide shall be fastened with two (2) galvanized framing nails 2" (51 mm) in length or two (2) 1 ¾ "(45 mm) coated screws. Decking shall be at least 11/16" (17mm) thick when placed on joists spaced 16" (400mm) on centre or less and 3/4 "(19 mm) thick when placed on joists spaced 24" (600mm) on centre.

Fasteners: Must be treated or coated to prevent corrosion. Screws may be used in lieu of nails so long as they provide equal strength.

Stairs: Shall have a width not less than 36" (900mm). Risers shall be a minimum of 4 7/8 "(125mm) and a maximum of 7 7/8 "(200 mm). Treads shall be a minimum of 9 ¼ "(235 mm) and a maximum of 14" (355mm). Stringers shall consist of a minimum 2x10 (38mm x 235 mm) lumber.

Railings: Shall conform to Supplementary Standard SB-7 of the Ontario Building Code.

Guards: Exterior guards shall not be less than 36" (900 mm) high when the walking surface served by the guard is not more than 5'-11" (1.8m) above finished grade otherwise the guard shall not be less than 42" (1070 mm) high. If a bench is incorporated into the guard then the required height is measured from the bench surface [OBC9.8.8.3.] Opening in the guard balusters shall be the size that will prevent the passage of a spherical object having a diameter of 4" (100 m) [OBC 9.8.8.5.] Guards shall be designed so that no member, attachment or opening will facilitate climbing [OBC 9.8.8.6.] (refer to SB7)

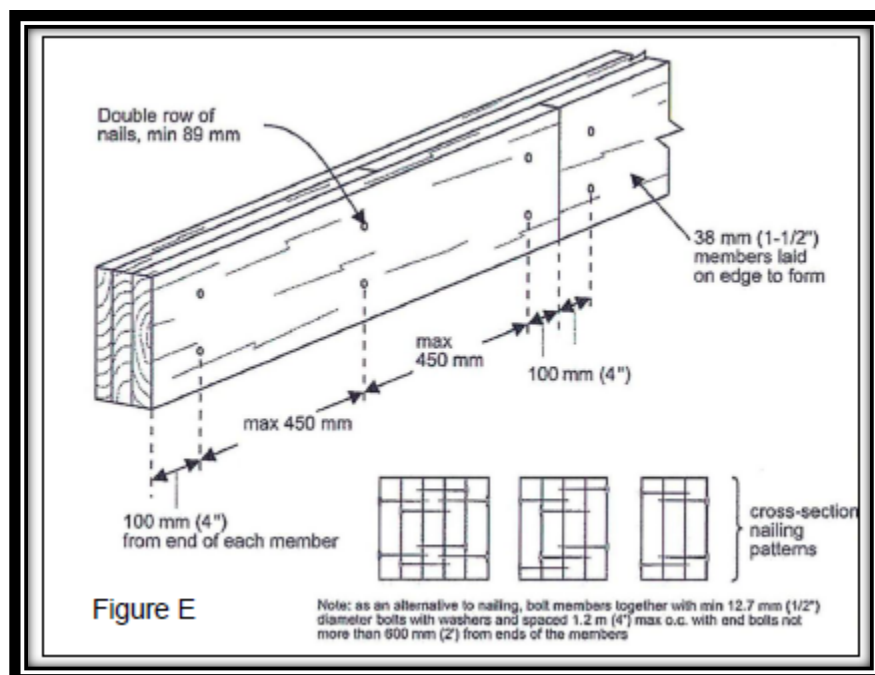

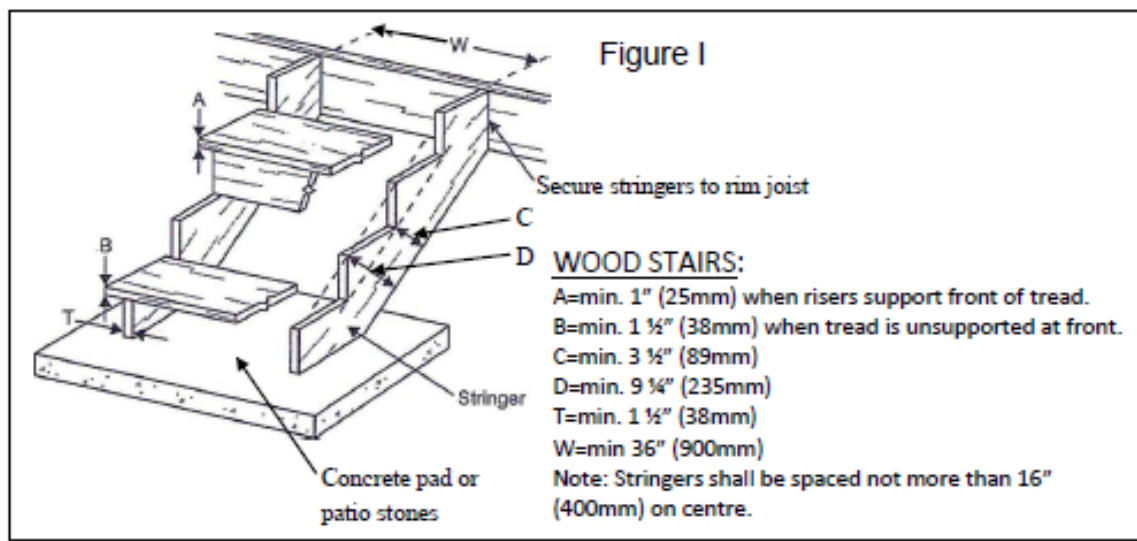
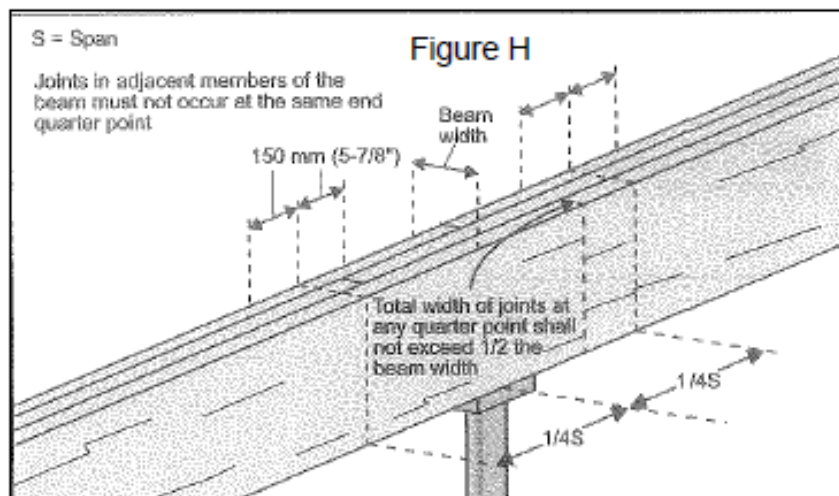
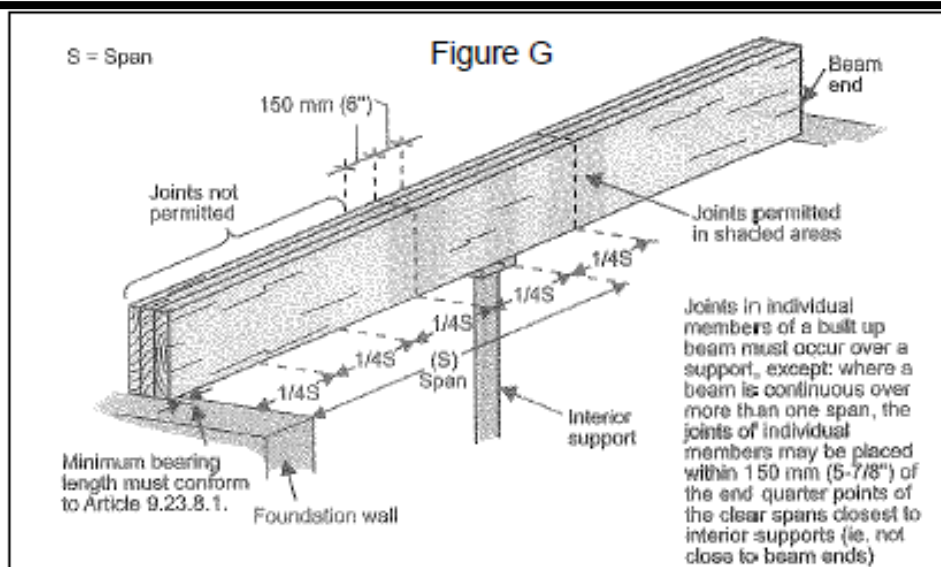

LEDGER BOARD CONNECTION

LEDGER BOARD CONNECTION TO RIM BOARD

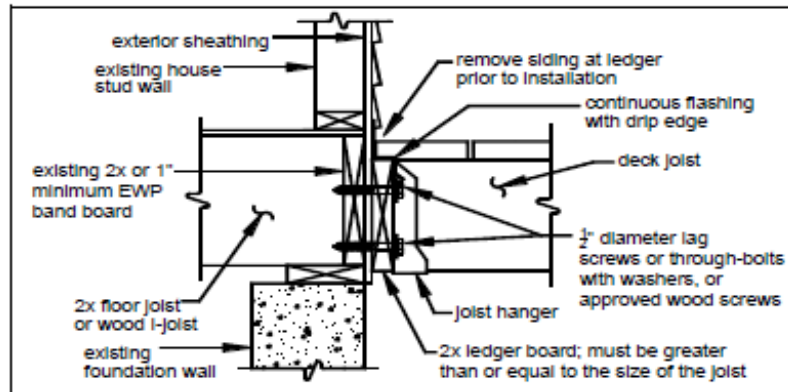

LEDGER BOARD CONNECTION TO POURED FOUNDATION WALL

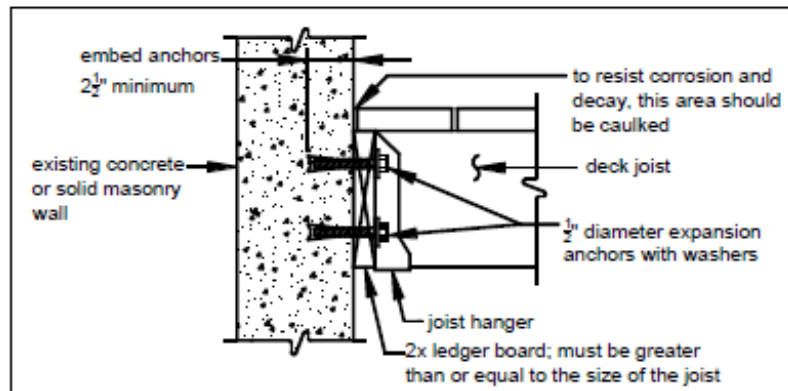

LEDGER BOARD CONNECTION TO BLOCK WALL

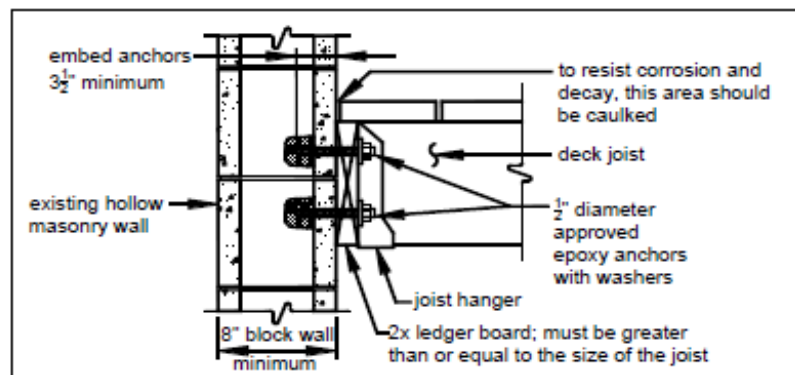

Note: Ensure anchors into solid masonry of block or through bolt with a carriage bolt. Top course of hollow block is typically core filled. Ensure anchors are into solid masonry or web of hollow block. Alternatively, install a carriage bolt through ledger board and block.

SECTION THROUGH STAIR

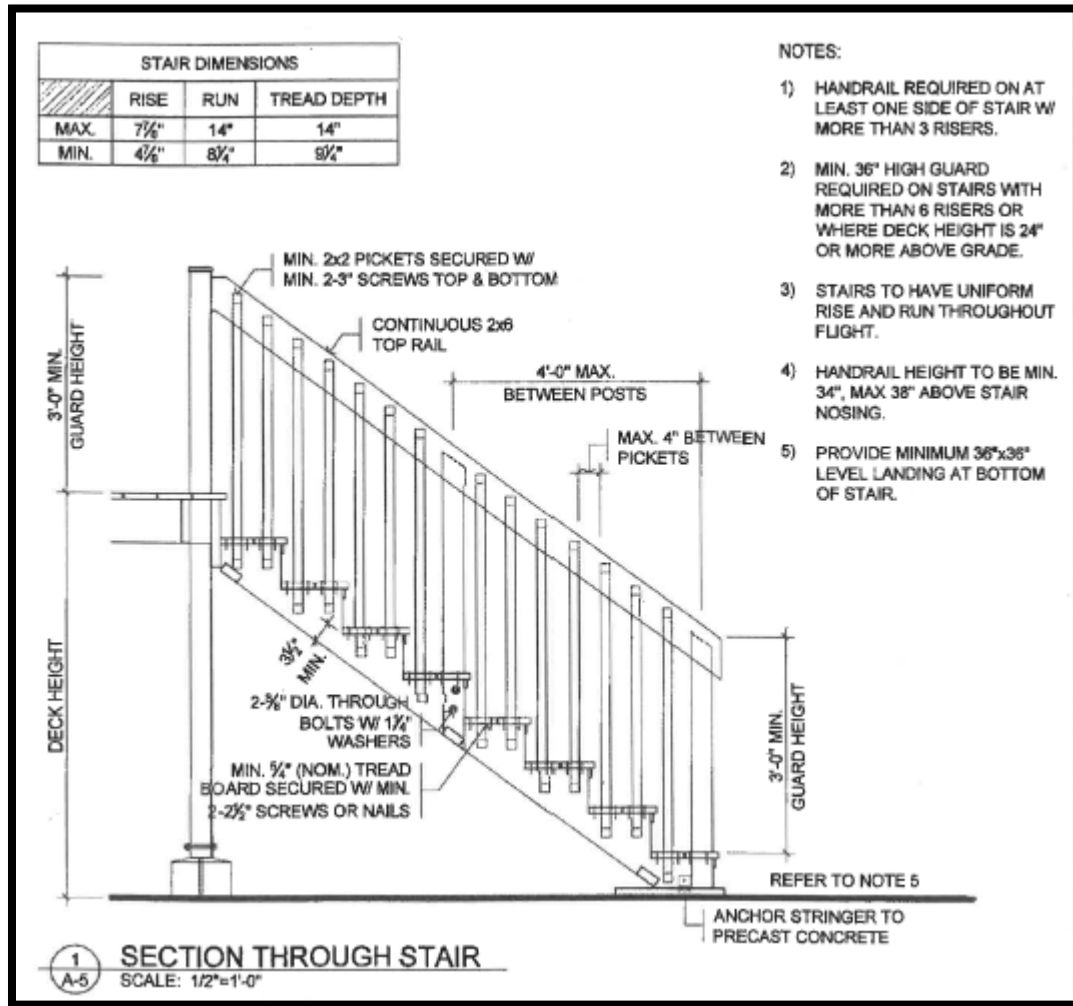

EXAMPLE DECK PLAN AND SECTION DRAWING

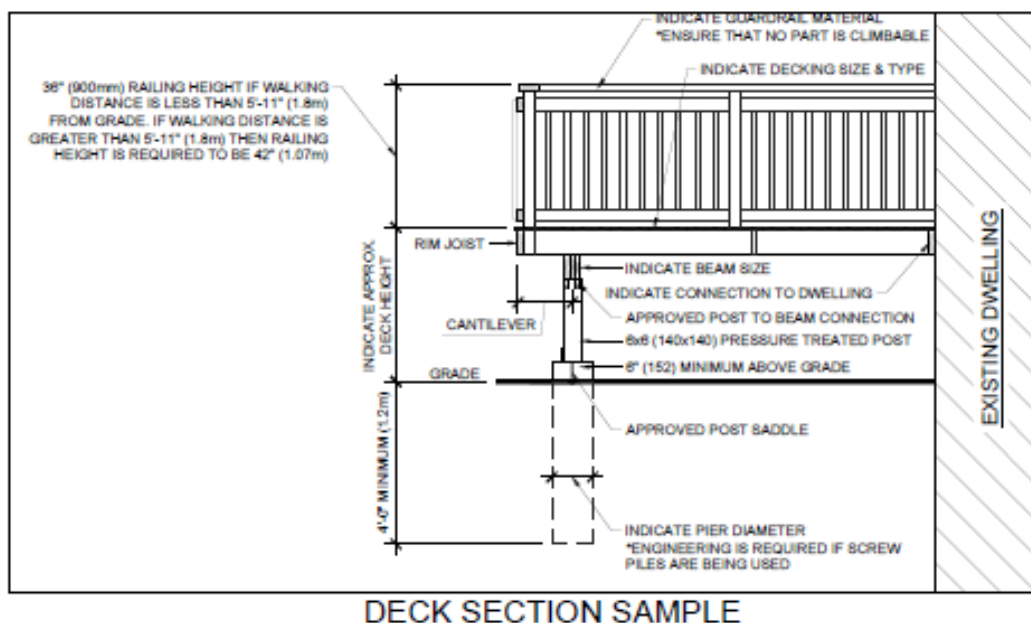
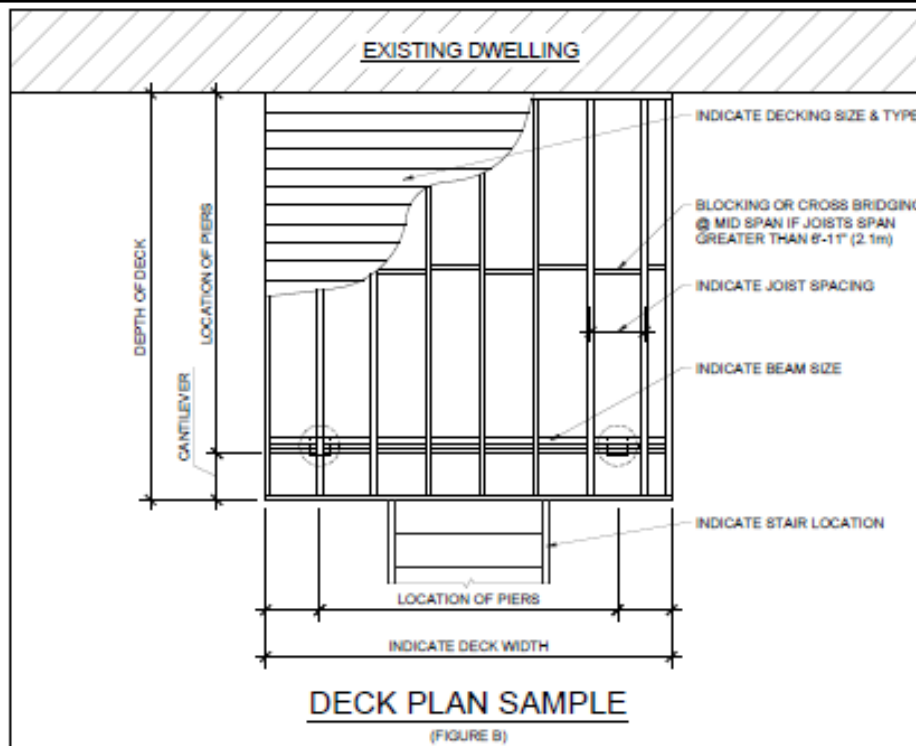

DECK CONNECTION

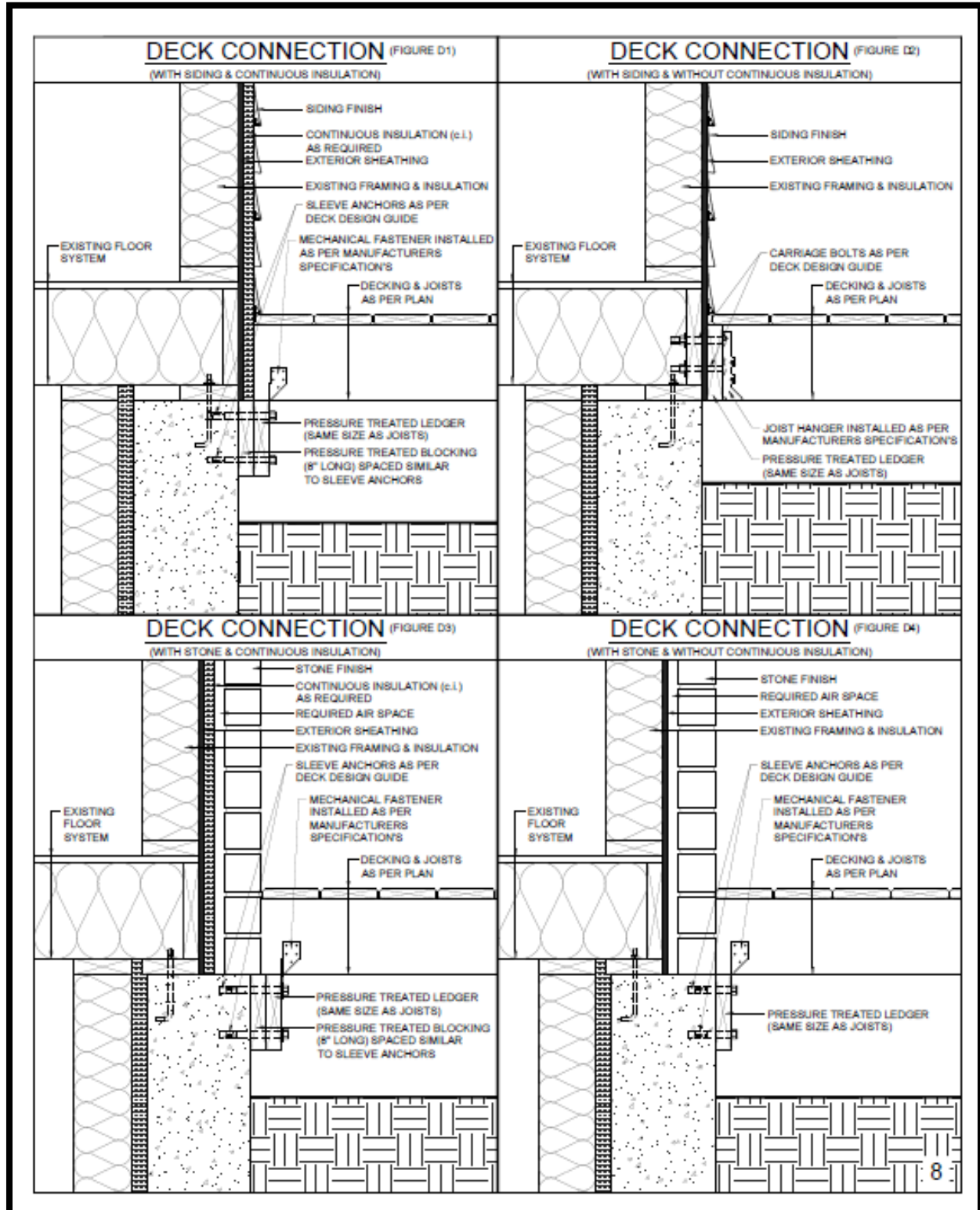

SAMPLE SITE PLAN

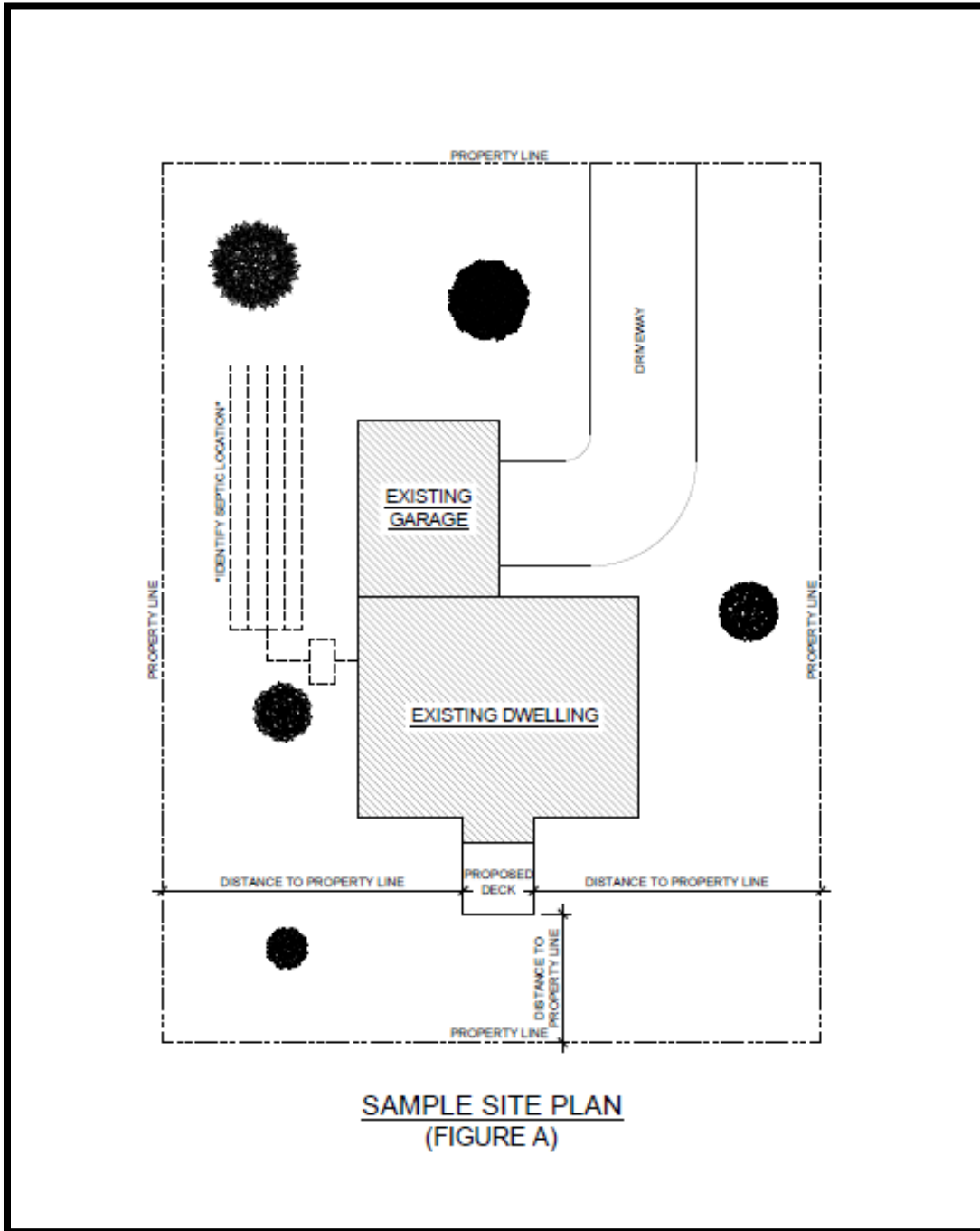

SAMPLE SITE PLAN
(FIGURE A)

**site plan must show all measurements requested and be accurate*

ONTARIO BUILDING CODE – SB-7

2012

MMAH Supplementary Standard SB-7

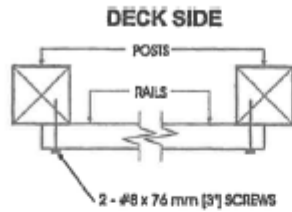

Table 2.2.1.
Exterior Post and Rail System Connection Details

Connection Detail	Detail Number	Description
Top Rail to Post and / or Bottom Rail to Post	EA-1	Top rail nailed to post
	EA-2	Top/bottom rail skew nailed to post with 76 mm (3") nails
	EA-3	Top/bottom rail skew nailed to post with 63 mm (2½") nails
	EA-4	Top/bottom rail face nailed or screwed to post
	EA-5	Top/bottom rail fastened to post with framing anchors
Post to Floor	EB-1	Post nailed to rim joist
	EB-2	Post screwed to rim joist
	EB-3	Post bolted to floor joist with 8 mm (5/16") machine bolts
	EB-4	Post bolted to floor joist with 9.5 mm (3/8") machine bolts
	EB-5	Post bolted to 2 floor joists
	EB-6	Post fastened to floor, where guard is parallel to floor joists
Infill Picket	EC-1	Picket nailed to endcap; endcap screwed to rail
	EC-2	Picket nailed to rail
	EC-3	Picket screwed to rail
	EC-4	Picket screwed to top rail and rim joist
Column 1	2	3

Table 2.2.2.
Exterior Cantilevered Picket System Connection Details

Connection Detail	Detail Number	Description
Cantilevered Picket (Douglas Fir-Larch, Spruce-Pine-Fir, Hem-Fir Species)	ED-1	Picket screwed to rim joist
	ED-2	Picket screwed to rim joist, where guard is parallel to floor joists
Cantilevered Picket (Northern Species)	ED-3	Picket screwed to rim joist and deck
	ED-4	Picket screwed to rim joist and deck, where guard is parallel to floor joists
Cantilevered Picket (Douglas Fir-Larch, Spruce-Pine-Fir, Hem-Fir Species, Northern Species)	ED-5	Corner
Column 1	2	3



PLAN

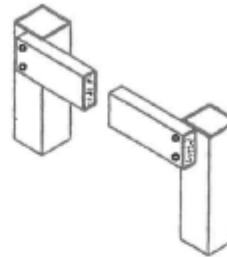

AXONOMETRIC

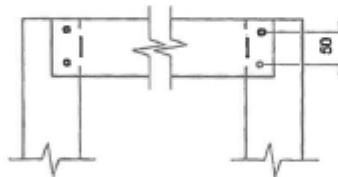

FRONT ELEVATION

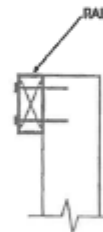

SIDE ELEVATION

Detail EA-4

Exterior Connection: Top/Bottom Rail Face Nailed or Screwed to Post

Notes:

1. If the rails are located on the deck side of the posts, 76 mm (3") nails may be used in place of the screws.
2. Where the top rail is continuous, the top rail may be fastened to each post with 3 - #8 x 76 mm (3") screws.
3. Dimensions shown are in mm unless otherwise specified.

MAXIMUM SPAN OF RAIL BETWEEN POSTS	
Species	Maximum Span, m (ft-in)
Douglas Fir-Larch, Hem-Fir, Spruce-Pine-Fir	1.77 (5'-10")
Northern Species	1.41 (4'-8")
Column 1	2

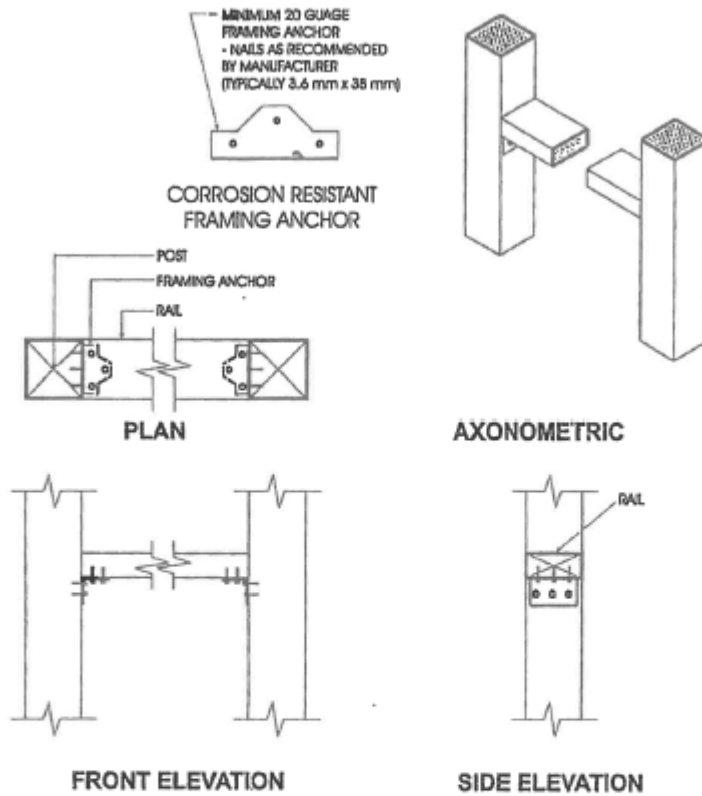

Detail EA-5

Exterior Connection: Top/Bottom Rail Fastened to Post with Framing Anchors

Notes:

1. Provide support to bottom rail at intervals not more than 2.0 m (6'-7").
2. The bottom rail may be bevelled as detailed in Figure 2.1.2.
3. Dimensions shown are in mm unless otherwise specified.

MAXIMUM SPAN OF RAIL BETWEEN POSTS	
Species	Maximum Span, m (ft-in)
Douglas Fir-Larch, Hem-Fir, Spruce-Pine-Fir	2.72 (8'-11")
Northern Species	2.18 (7'-2")
Column 1	2

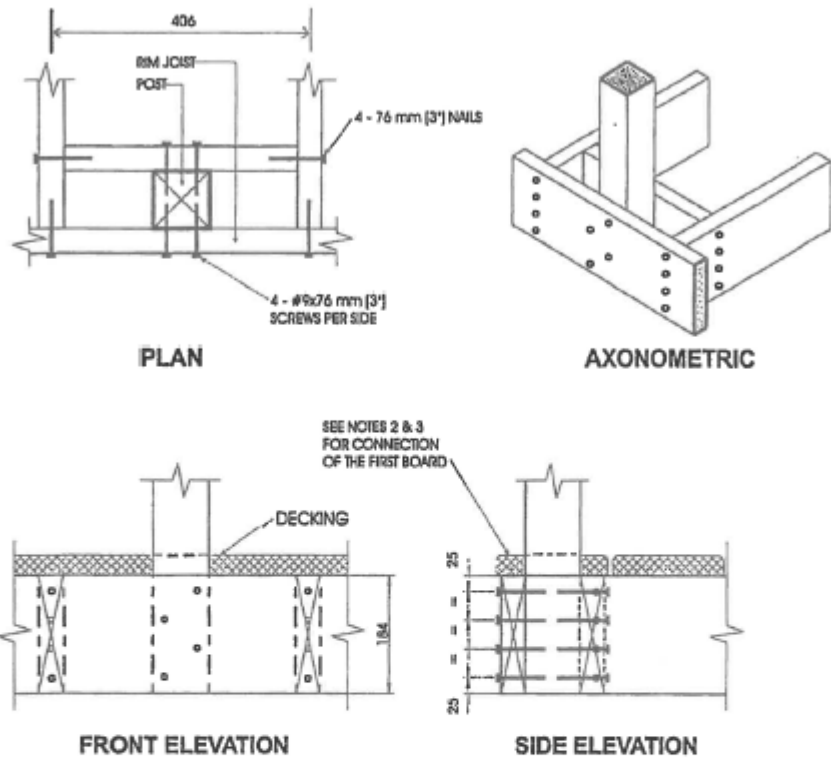

Detail EB-2
Exterior Connection: Post Screwed to Rim Joist

Notes:

1. Decking is omitted from the plan view and the axonometric view for clarity.
2. Fasten 25 mm x 140 mm (5/4" x 6" nominal) outer deck board to rim joist with 63 mm (2 1/2") nails at 300 mm (12").
3. Fasten 25 mm x 140 mm (5/4" x 6" nominal) outer deck board to floor joist with 1 - 63 mm (2 1/2") nail at each joist.
4. The post may be positioned anywhere between the joists.
5. #9 screws may be replaced by #8 screws if the maximum spacing between posts is not more than 1.20 m (3'-11").
6. Dimensions shown are in mm unless otherwise specified.

MAXIMUM SPAN OF RAIL BETWEEN POSTS	
Species	Maximum Span, m (ft-in)
Douglas Fir-Larch, Hem-Fir, Spruce-Pine-Fir	1.56 (5'-1")
Northern Species	1.20 (3'-11")
Column 1	2

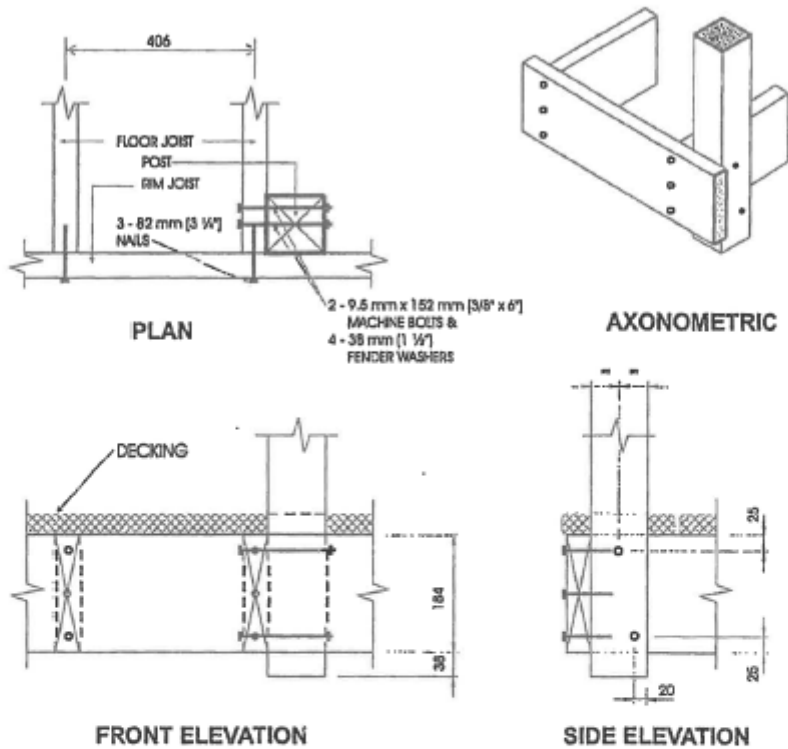

Detail EB-4

Exterior Connection: Post Bolted to Floor Joist - 9.5 mm (3/8") Bolts

Notes:

1. Decking is omitted from the plan view and the axonometric view for clarity.
2. 38 mm (1 1/2") post projection is not required where the maximum spacing between posts does not exceed 1.20 m (3'-11").
3. Joists may be spaced at 610 mm (24") o.c. or 406 mm (16") o.c.
4. Where floor joists are spaced at 610 mm (24") o.c., decking shall have a minimum thickness of 38 mm (1 1/2") and shall be fastened to the floor with 2 - 76 mm (3") nails.
5. Dimensions shown are in mm unless otherwise specified.

MAXIMUM SPACING BETWEEN POSTS	
Species	Maximum Span, m (ft-in)
Douglas Fir-Larch, Hem-Fir, Spruce-Pine-Fir	1.49 (4'-11")
Northern Species	1.20 (3'-11")
Column 1	2

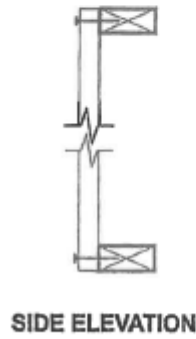
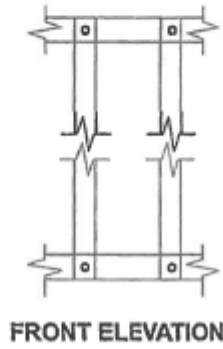
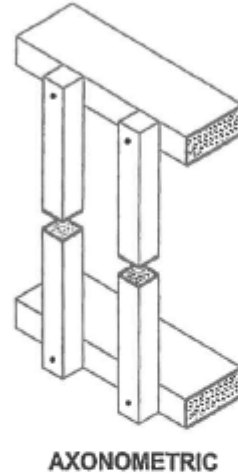
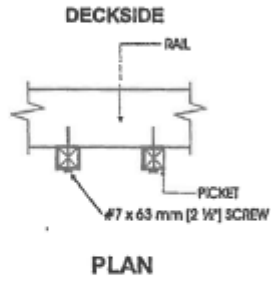

Detail EC-3
Exterior Connections: Infill Picket Screwed to Rail

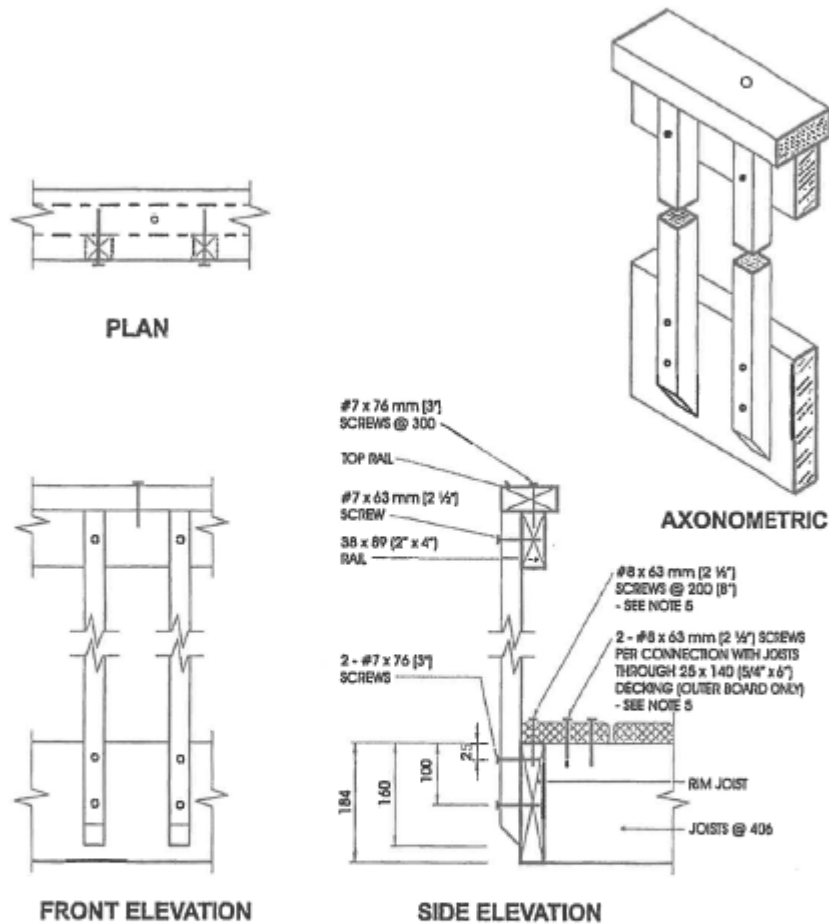
**Detail ED-1****Exterior Connection: Cantilevered Picket Screwed to Rim Joist****Notes:**

1. Provide a suitable post, return, or solid support at each end of the guard.
2. Wood for cantilevered pickets shall be Douglas Fir-Larch, Spruce-Pine-Fir, or Hem-Fir Species.
3. Fasten rim joist to each floor joist with 3 - 82 mm (3 1/4") nails.
4. Dimensions shown are in mm unless otherwise specified.
5. The outer deck board shall not be less than 140 mm (6" nominal) wide. Where 38 mm (2" nominal) thick boards are used, the length of the wood screws shall be not less than 76 mm (3").

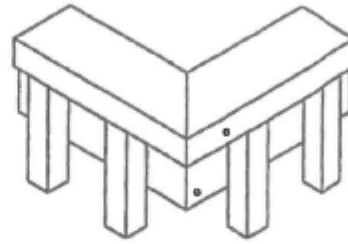
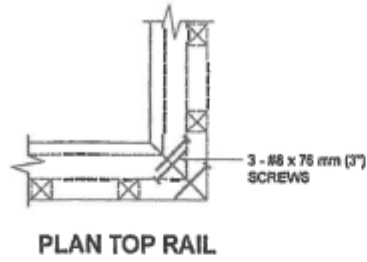

ONE FASTENER IN HORIZONTALLY ORIENTATED PORTION OF TOP RAIL
AND TWO IN VERTICALLY ORIENTATED PORTION.

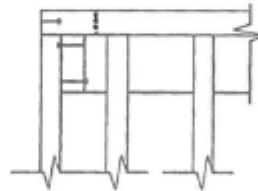
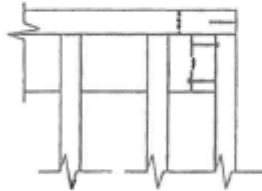

Detail ED-5
Exterior Connection: Corner Joint

Notes:

1. Screws fastening pickets are omitted for clarity.
2. Provide a minimum of 10 pickets beyond the return if end restraint of the guard is provided by this return detail only.